

## Custom ASIC, High Performance Fixed and Programmable Crypto Engine

### PRODUCT DESCRIPTION

The NSA Type 1 Certified unityCP<sup>®</sup>-1 belongs to a family of INFOSEC ASIC devices for embedment applications in harsh environments. The device has been implemented with a true multi-processor architecture supporting multiple simultaneous algorithms at high data rates. The unityCP<sup>®</sup>-1 enables compliance with the DoD Crypto Modernization Initiative and supports crypto modern and legacy algorithms with low power operation in a small package. The unityCP<sup>®</sup>-1 is available with a certified software library, providing users the capability to integrate into custom configurations.

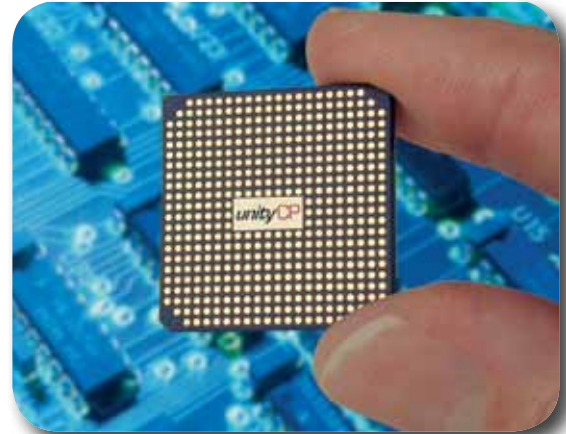

Algorithm Interoperability:  
FASTLANE, TACLANE, STE/OMNI, KGV-136

Interoperable with Added External Node:  
AES, KG-84, KG-194(A), KIV-7M, KIV-19M, KY-99(A), KGV-11, KI-37, KY-68

### FEATURES

- NSA Type 1 Certified up to TS/SCI
- Space RAD Hardened or Terrestrial Package Options
- QML-V and QML-Q Versions
- Embeddable-Unclassified & CCI ASIC
- Programmable Crypto Engine
- High Speed Data Rate
- High Grade-High Assurance
- Key Management Configurable
- Simultaneous Crypto Algorithm Support
- Crypto Modernization Ready
- AEHF TRANSEC/COMSEC Interoperable
- Backward Compatible Legacy Interoperable

### APPLICATIONS

- Avionics/Airborne
- Media
- Secure Networks
- Space
- Software Configurable Radios
- Telephony

## Custom ASIC, High Performance Fixed and Programmable Crypto Engine

### FEATURES

- General Purpose Processor
  - 32 Bit RISC Processor Core
  - High Speed Multiplier and Modular Math Accelerator
- On Board Non-Deterministic Randomizer
- High Bandwidth Type I Crypto Algorithms
  - BATON: up to 300 Mbps
  - MEDLEY: up to 200 Mbps
- Expansion Node Interface: Supports up to Eight (8) Application Specific External Co-Processors

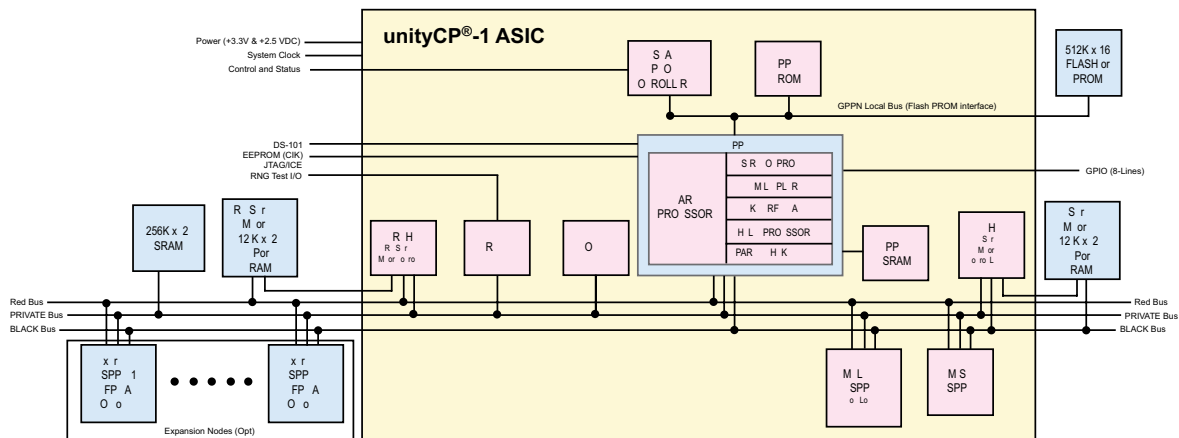

- Built in Interfaces for CIK Based Access Control and DS101 Fill Devices
- Key Management
  - 1024 Operational Keys
  - Black, Benign, Red Key Fill Supported
  - FIREFLY 9/17, ACCORDION, JOSEKI
  - High Speed Caching Support: 400 keys/sec Typical
- Flexibility:
  - Secure Software Download via KM-TG-0002 Authentication
  - Expansion Interface Supports Fixed or Dynamic FPGA Based Co-processing
  - Software Libraries of Common Functions
  - Combination of Hardware Processing and Software Control Maximizes Speed, Flexibility, and Interoperability
- Security Features
  - High Grade/High Assurance Fail Safe Design
  - Supports CIK Based Access Control with up to Eight (8) CIKs
  - Supports Bulk, Serial or Packet Encryption
- Power Management
  - Selectable to Match Operating Mode
  - Lower Power in Idle Mode
- On Chip Oscillator, Time of Day, Battery Region

### Communication Systems-East

1 Federal Street  
 Camden, NJ 08103  
 Tel: 856-338-3505  
 email: Fred.Barnum@L-3Com.com  
 www.L-3Com.com/unityCP