

## L-3 IOT 60T UHF-TV Transmitter Tube & Trolley

The Inductive Output Amplifier is a high-efficiency tube operating in the UHF-TV frequency range of 470 to 810 MHz. The amplifier can be used in digital transmitters and in analog transmitters requiring combined vision/aural service, vision only service, and aural only service.



Ratings	Min.	Max.	Units
Heater Voltage	5	7	V
Heater Current (operating)	20	30	A
Heater Current (surge)	- - -	60	A
Heater Warm-Up Time	300	- - -	sec
Beam Voltage	22	32	kV
Beam Current (mean)	- - -	2.5	A
Quiescent Current	0.4	0.6	A
Body Current	- - -	50	mA
Solenoid Current	22	26	A
Collector Dissipation	- - -	40	kW
Load VSWR	- - -	1.5:1	- - -
Bias Voltage (ref. to cathode)	-50	-150	V
Grid Current	- - -	±150	mA
Ion Pump Current (beam on)	- - -	20	μA
Ion Pump Voltage (ref. to cathode)	3	4	kV
Drive Power for Visual Service Peak Sync.	- - -	450	W
Instantaneous Peak Output Power	- - -	76	kW
Peak Sync. Vision Only Output Power	- - -	64	kW
Aural Only Output Power	- - -	30	kW
Peak Sync. Vision Output Power Common Mode	- - -	44	kW
Aural Output Power Common Mode	- - -	4.4	kW
Peak/Average Output Power (8VSB)	- - -	85/20	KW/kW
Peak/Average Input Power (8VSB)	- - -	950/160	W

### Mechanical Specifications

<b>IOT —</b>		Net Weight of Magnet Assembly (approx.)	250 lb
Mechanical Outline IOT	See back	Cooling:	
Mounting Position	Collector end down	Maximum Inlet Pressure	60 psi
Weight (approx.)	50 lb	Maximum Inlet Water Temperature	55°C
<b>Trolley Assembly —</b>		Maximum Outlet Water Temperature	75°C
Mechanical Outline IOT	See back	Min. Collector Flow (RO or DI water)	14.5 gpm
Electromagnet Voltage	5–7 V	Collector Pressure Drop	40 psi
Electromagnet Current	22–27 A	Minimum Body Flow (RO or DI water)	1.3 gpm
RF Input	Type N	Air Flow to Input and Output Cavities	90 cfm
RF Output	3 1/8" 50-Ω coaxial line	Air Pressure at Intake	5"
Net Weight of Tuning Cavities (approx.)	110 lb	Maximum Air Temperature at Intake	60°C

### Tube Protection:

A photoresistor-type arc detector is fitted to each of the primary and secondary output cavities. The beam voltage must be removed within 100 ms of an arc being detected.



communications

Electron Devices

# L-3 IOT 60T UHF-TV Transmitter Tube & Trolley

## Outline Drawings

### Focus Coil Connections

#### Pin Element

- A Focus Coil Positive
- B Lid Switch
- C Focus Coil Negative
- D Lid Switch

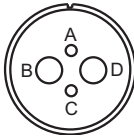

Note: Pins B and D are connected within the circuit assembly for use as an interlock circuit.

### Lid Switch Interlock Connections

#### Pin Element

- A Lid Switch
- B Not Connected
- C Lid Switch

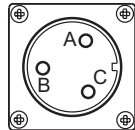

### Arc Detector Connections

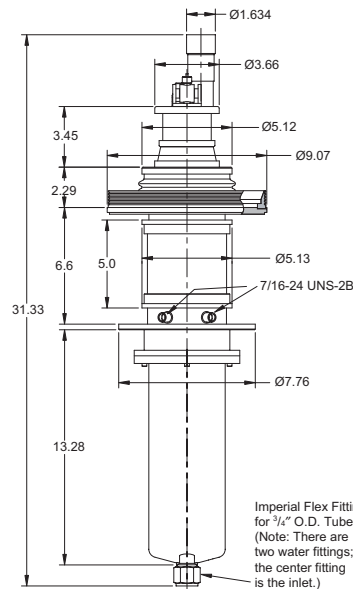
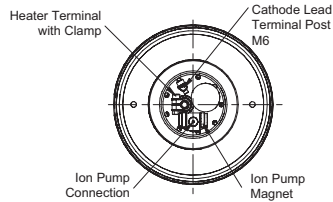
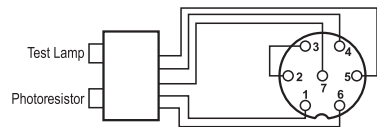

IOT Outline

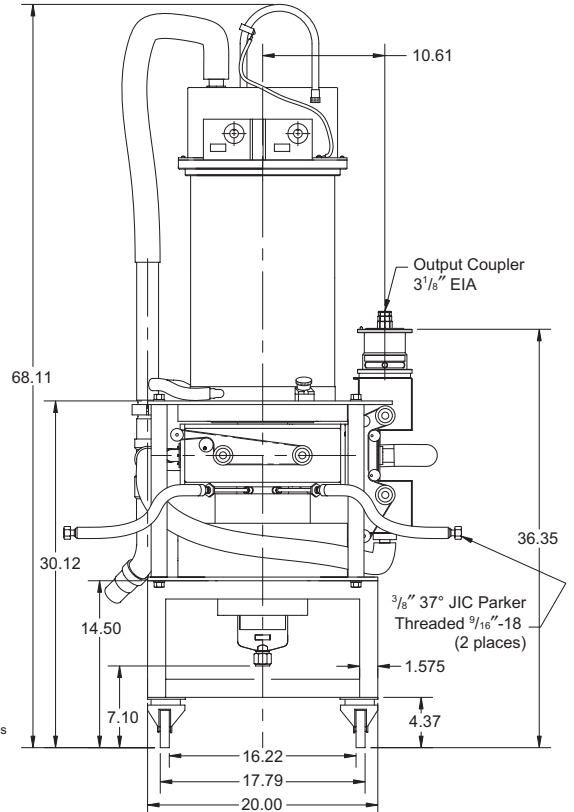

Front View of Trolley Assembly

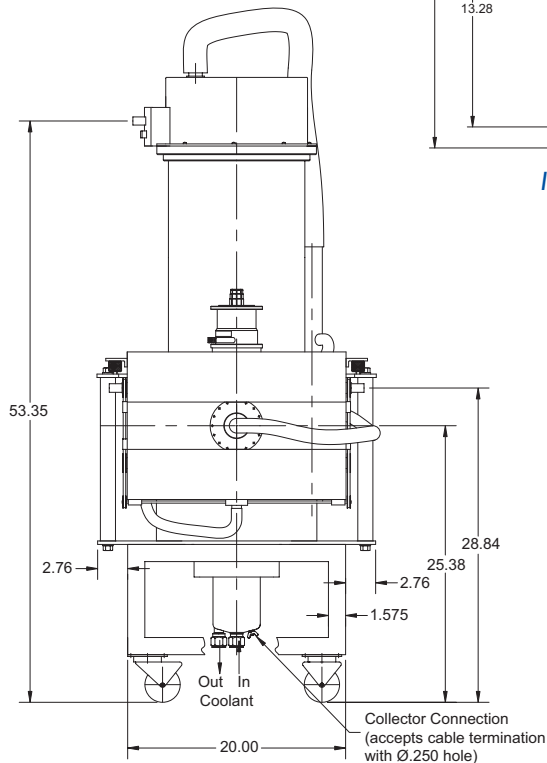

Side View of Trolley Assembly

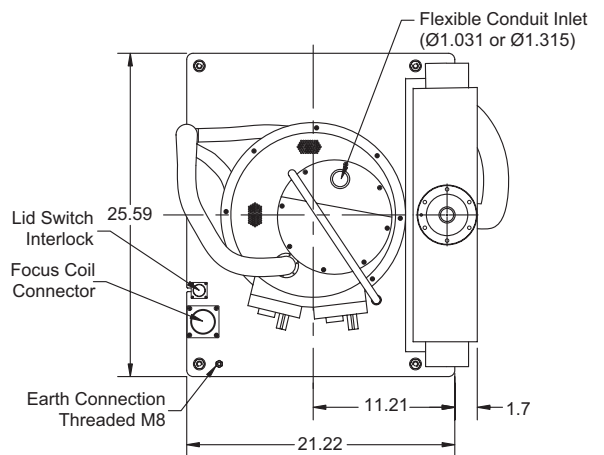

Top View of Trolley Assembly

### L-3 Electron Devices

1035 Westminster Drive  
Williamsport, PA 17701  
570.326.3561  
800.861.1848

Fax: 570.326.2903 e-mail: marketing@electrondevices.com



communications

Electron Devices

Characteristics and operating conditions are based upon performance tests. These values may change as the result of further data or product refinement. L-3 Electron Devices should be consulted before using this information for product design.

www.L-3Com.com/edd