



# Mil-Spec Indicators

## Rear and Front Mount Qualified to MIL-PRF-83287/2

### FEATURES

- Electrical Reset
- Magnetic Latching
- Positive Identification
- Environmentally Sealed

The M83287/2 magnetic latching fault indicator displays a highly visible dual color internal flag when the indicator coil is pulsed by a BITE (Built-in Test Equipment) system. The “cloverleaf” pattern provides a high contrast visual identification and an effective warning of system results.

### OPERATION

When the indicator coil is energized with a 40 millisecond (or longer) pulse, the highly visible display disc rotates and latches to the magnetic core. The display disc will remain magnetically latched to the core in the position last pulsed. Even if the fault signal is removed, the indicator will “remember” that a fault had occurred.

Return to the “No-Fault” position is accomplished electromechanically by pulsing a separate coil.



### ELECTRICAL SPECIFICATIONS

See table below for Voltage and Resistance values.

**Pulse Power:** One Watt. Nominal

**Pulse Length:** 40 milliseconds, minimum

**Dielectric Withstanding Voltage:** 500 VAC RMS.

**Insulation Resistance:** 100 megohms minimum at 500 VDC.

**Electromagnetic Interference and Magnetic Susceptibility:**

Per MIL-PRF-83287. The units will not malfunction of false transfer when subjected to a 20 ampere turn field at 400 Hertz.

### MECHANICAL SPECIFICATIONS

**Case:** Black, anodized aluminum.

**Mounting:** Front panel by mount (D-hole or keyed washer).

**Weight:** MIL Unit 20 grams

**Display Colors:** “NO-FAULT” is black, “FAULT” is black/white

**Leads:** WL-Eight inches of #26 AWG Teflon insulated wire leads  
LT- Loop Terminals

### ENVIRONMENTAL SPECIFICATIONS

**Operating Temperature Range:** -65°C to + 125°C.

**Vibration\*:** Sinusoidal: .06" D.A. or 20 G Peak, whichever is less,

10 Hz to 2 kHz per MIL STD 202, Method 204, Test Condition D.

**Random:** 11.6 G's per MIL STD 202, Method 214, Test Condition D, Curve 1.

**Shock:** 100 G's MIL STD 202, Method 213, Test Condition I.

**Moisture Resistance:** (Humidity): MIL STD 202, Method 106.

**Thermal Shock:** MIL STD 202, Method 107, Test Condition B.

**Salt Spray:** MIL STD 202, Method 101, Test Condition B.

**Barometric Pressure:** MIL STD 202, Method 105, Test Condition D, with 350 Volts AC, RMS.

**Life:** 100,000 cycles at cycling rate of 10 per minutes.

*\*During vibration testing caution should be taken to shield the indicator from the strong magnetic field.*

Optional: RFI panel shielding available

Covered by U.S. & Foreign Patents

### Military Product Ordering Information

When ordering military spec product, use the basic MIL number as identified on page 26. Example: M83287/2-01

Basic Part Number	Standard Glass				Non-Glare Glass				Rated Voltage	Coil Resistance		Configuration
	Wire Leads		Loop Terminals		Wire Leads		Loop Terminals			OHMS		
	Diodes		Diodes		Diodes		Diodes		DC	Ambient		
	W/Out	With	W/Out	With	W/Out	With	W/Out	With		Min	Max	
	Dash Number				Dash Number					Min	Max	
M83287/2	-01	-02	-03	-04	-05	-06	-07	-08	28	675	880	A
M83287/2	-09	-10	-11	-12	-13	-14	-15	-16	28*	360	500	A
M83287/2	-17	-18	-19	-20					28	375	850	A
M83287/2	-21		-22		-23		-24		28	675	880	B
M83287/2	-25		-26		-27		-28		28*	360	500	B
M83287/2	-29	-30	-31	-32	-33	-34	-35	-36	12	130	230	A
M83287/2	-37		-38		-39		-40		12	130	230	B
M83287/2	-41	-42	-43	-44	-45	-46	-47	-48	5	19	35	A
M83287/2	-51		-52		-49		-50		5	19	35	B

\*FOR USE WITH UNREGULATED POWER SUPPLY (MIL-STD-704)

# MIL-Spec Indicators

## Rear and Front Mount

### Qualified to MIL-PRF-83287/2

Short case model MI 57DA available for non-military applications. See page 13.



Configuration A  
Rear Mount

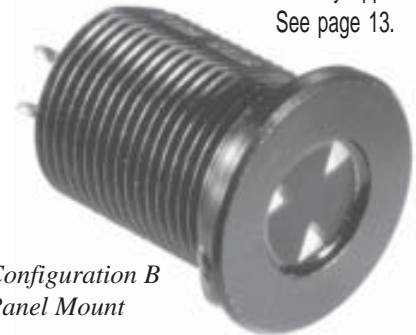

Configuration B  
Panel Mount

### Configuration A Rear Mount

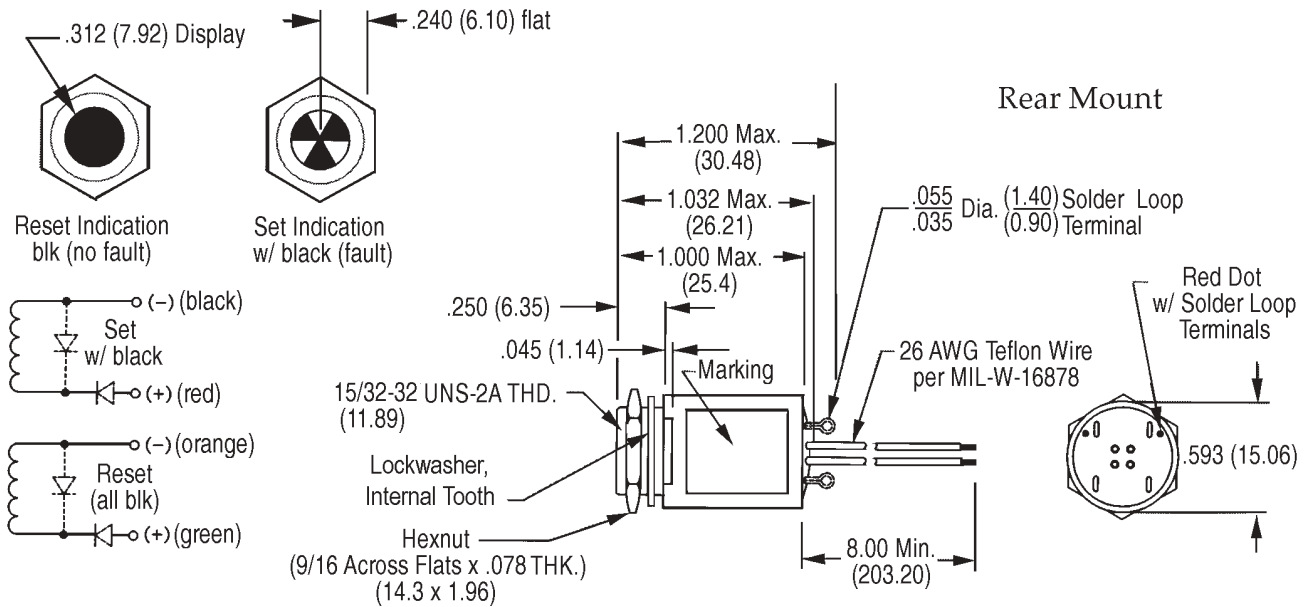

### Configuration B Front Mount

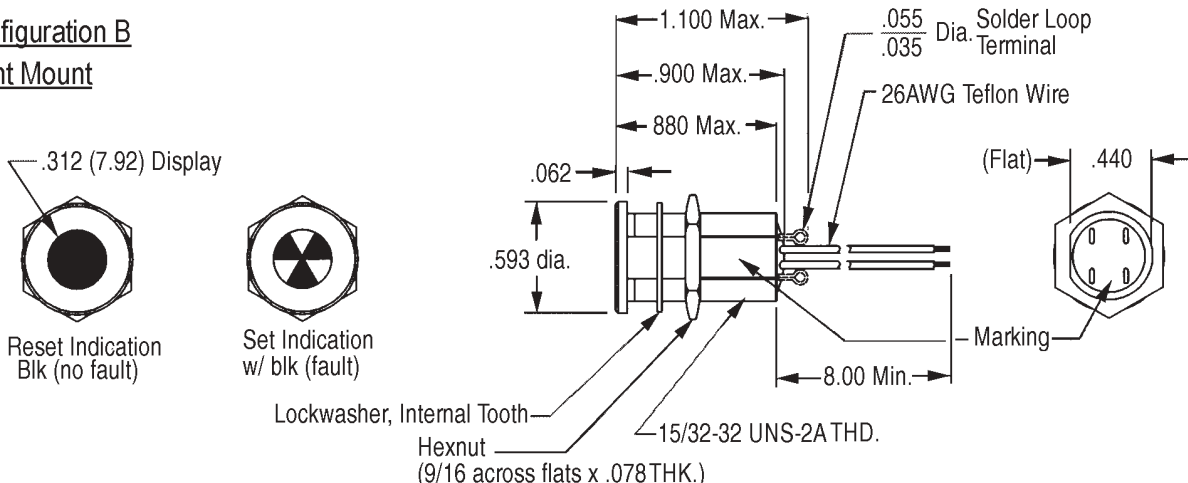

**NOTE:**

Dimensions in ( ) are mm. Tolerances: Decimals: ± .010 (0.25), Fractions: ± 1/64—All mounting hardware is black anodized aluminum. Mounting Torque: 5-7 in. lbs.