



The Dynatime® Digital Series

Solid State, Panel Mount Hour Meters & Event Counters

FEATURES

- Monitors your system usage
- Panel Mount Configuration
- Non-Volatile Memory
- Qualified to MIL-M-7793/14
- Download readings to Palm™ PDA

DDS200 Series

The DDS200 solid-state Hour Meter and the DDS201 solid-state Event Counter have been developed to meet the most difficult requirements of military and aerospace applications. In one panel mount package, the DDS200 series provides a highly reliable means of monitoring critical system usage, important for proper equipment maintenance.

The elapsed time and events data can be read via the M7793/12 reader or through the newly developed Palm™ PDA compatible interface cable and software. With the Palm interface cable the readings from multiple devices can be downloaded and stored in an Excel™ compatible file that can be synchronized with a laptop or desktop computer. This allows the data to be used more effectively for analysis of system usage. The interface cable is compatible with all existing M7793/14 hour meters and event counters.

The time range for the DDS200 Hour Meter is 99999.99 hours. It has also been approved to MIL-M-7793/14. The DDS201 Event Counter has been successfully tested to the requirements of MIL-M-7793/14 and records counts when the unit receives power for greater than 5 seconds. Power-on times of less than 4 seconds will not cause the counter to increment. The count range is 9,999,999.



Model DDS200: Hour Meter
Model DDS201: Event Counter



Palm™ PDA Interface Cable Assembly for extraction of solid state Hour and Event Meter data. Downloads using 16 pin Palm universal connector.

Supports Palm M500 Series, Palm Zire 71, Tungsten T2, Tungsten T3 and others.

Requires software supplied with cable assembly. Cable length approximately 1 meter.

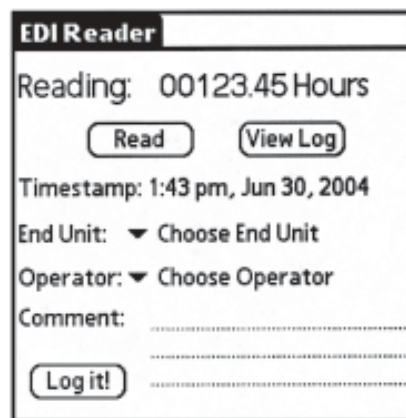

Specifications on reverse side

The Dynatime® Digital Series Solid State, Panel Mount Hour Meters & Event Counters

Mechanical Specifications

Case Dimensions: See below for detail dimensions.

Weight: 1 ounce max.

Hour Meter—Time Range: 99999.99 hours

Event Counter—Count Range: 9,999,999 counts

Meter Output: Serial binary coded decimal format.

Environmental Specifications

Operating Temperature Range: -65 to +125°C

Shock: MIL-STD-202, Method 213, Condition I

Vibration: MIL-STD-202, Method 204, Condition D

Salt Spray: MIL-STD-202, Method 101, Condition B

Moisture Resistance: MIL-STD-202, Method 106, Figure 106-1

Altitude: MIL-STD-202, Method 105, 0-80,000 feet

Electrical Specifications

These meters meet or exceed applicable requirements of MIL-M-7793 and M7793/14. Other ratings and configurations are also available.

Operating Voltage Range: 10-34 VDC and 20-30 VAC, 50-2400Hz.

Ripple Voltage: Operates normally when subjected to the ripple requirements of 5-2-2, 5-2-2-1 and Figure 7 of MIL-STD-704A.

Output Impedance: 100 k Ω \pm 10 %

Logic Zero: 0.0 to 0.2 V

Logic One: 3.3 to 6.6 V

Power Consumption: 50mW max. at 28VDC; 25mW max. at 26VAC 400Hz.

Transient Protection: No temporary or permanent degradation in meter when subjected to input voltage and time values shown in MIL-STD-704A, Figures 7 and 9, Curve 1 (600V and 80V transients, respectively).

Dielectric: Withstands 600VRMS (room) and 350 VRMS (altitude) applied between the power terminals and an external ground.

Insulation Resistance: MIL-STD-202, Method 302, Condition B

Accuracy: \pm 0.1% over temperature/voltage range

EMC: MIL-STD-462, Methods CE03 and RE02

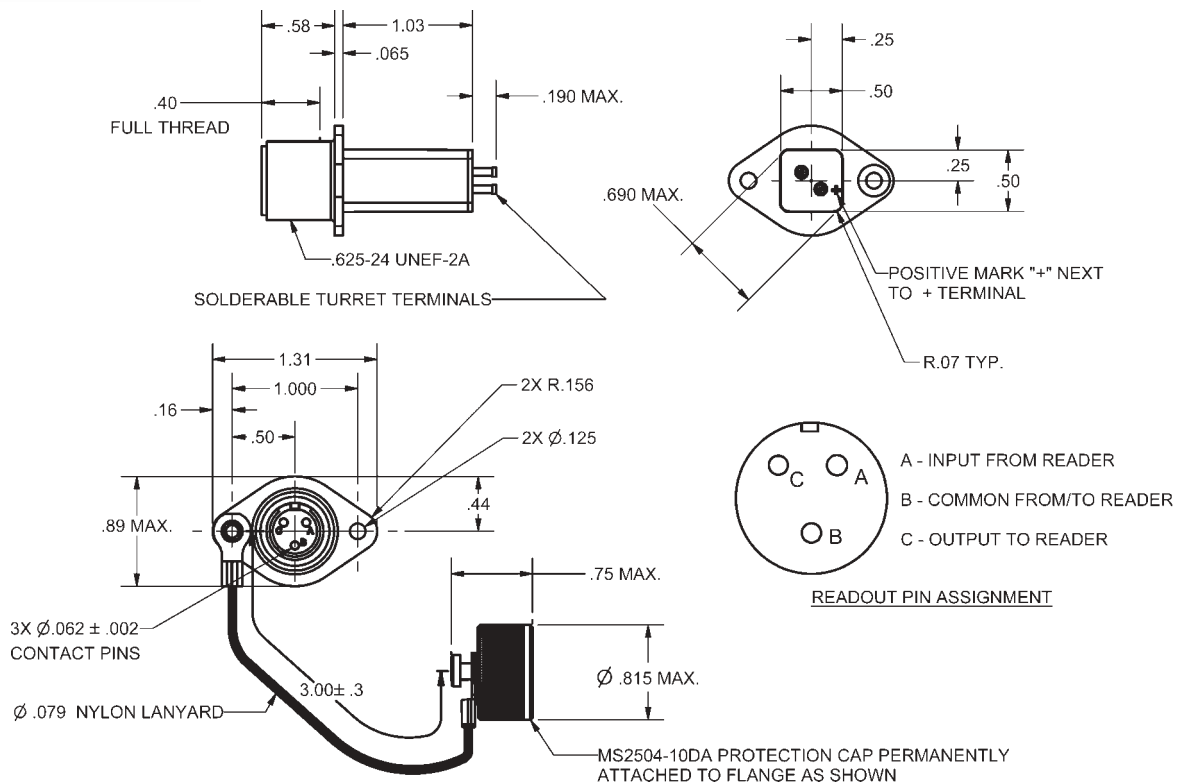

NOTE:

Dimensions in inches.

Tolerances: Decimals: \pm .02 for two-place decimals; \pm .015 for three-place decimals.