

Electronic Safe, Arm and Fire Device

FEATURES

- Acquires data on BIT disconnect, guidance and acceleration simultaneously
- Digital double-integration of acceleration
- Remains safe until safe separation distance is achieved, via integrator and backup timer
- Serial interface for delay programming and good-guidance input
- Sequence-checking on all environments
- High voltage arming from 28 VDC
- Crush switch interface and timers for precision delayed firings
- Exploding foil initiators using HNS-IV for high insensitivity
- BIT for safety verification
- Meets Army and Navy ESAF guidelines
- Passed qualification tests
- Lightning and ESD tests
- Two or three studs on cases
- Convection cooling

The L-3 Communications, Electroynamics (L-3/EDI) Electronic Safe, Arm and Fire (ESAF) device receives key vehicle, subsystem and environmental parameters from a missile, and validates them to safe, arm and fire two high explosive outputs. The ESAF computes safe separation distance from internal acceleration sensors to determine the arm distance. A high-voltage DC-DC converter arms the firesets and EFIs provide outputs. The ESAF was developed for the Hellfire II Missile System but can be easily adapted to other vehicles.

The ESAF is stud-mounted to the warheads and is suitable for use in a bomb, missile or undersea environment. It contains environment sensors, safe/arm logic, a high voltage DC-DC converter and one or two Exploding Foil Initiators with individual delay timers and firesets. This highly reliable unit has no moving parts or adjustments.

The validation function receives and checks signals for all environments simultaneously, enabling arming on proper sequence and time windows while also detecting complex disarm/dud conditions.

Unit built-in test is performed on power-up and results are reported to the missile. Downloading of delay data can be performed in-flight over a dedicated serial channel. A telemetry interface is provided for tests. The unit will cool itself by convection. The modular design of the ESAF permits easy reconfiguration to new applications. L-3 Communications, Electroynamics, a leader in solid-state safe/arm technology, has also produced electromechanical S&As for missiles, bombs, artillery and torpedoes.

Electronic Safe, Arm and Fire Device

DESIGN

- MIL-STD-331— fuze testing
- MIL-STD-454—general
- MIL-STD-461—EMI
- MIL-STD-704—air vehicle power
- MIL-STD-810—environmental test
- MIL-STD-1316—fuze safety
- MIL-STD-1385—HERO
- MIL-I-23659—initiators



SPECIFICATIONS

- Size:** 5.5" dia. x 1" thick (main)
1.92" dia. x 1.18" thick (remote module)
- Weight:** 620 grams-main with remote module and 6-foot cable
- Color:** Natural metal color
- Power:** +15 VDC @ .75 watts and +28 VDC @ 33 watts (arming only)
- Delays:** microseconds to milliseconds
- Reliability:** 0.998 (initial) 0.984 (10 years)
- Life:** 120 hours operating, 10 years useful

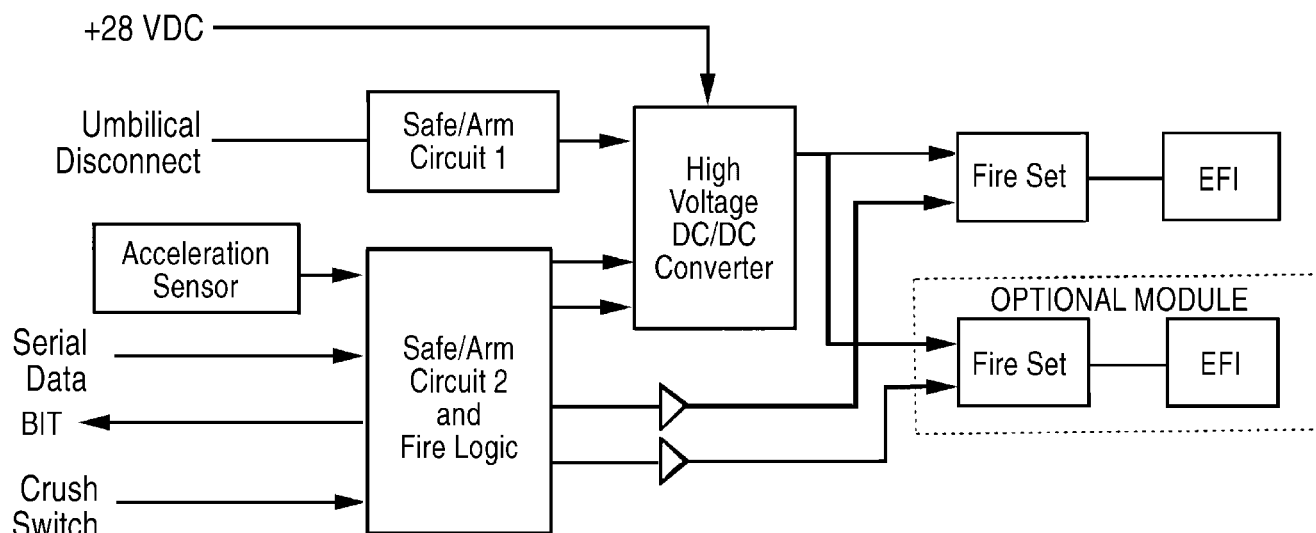

SYSTEMS