

Flight Data Recorder Processor

FEATURES

- Acquires data on six MIL-STD-1553 buses simultaneously
- Edits and saves selected data and events in external crash survivable memory unit
- Remote Terminal interface for device control and data acquisition.
- Up to 2 KB per second storage rate
- Error-checking on all storage operations
- Uploadable program and configuration areas
- Extraction over RS-422 bus or 1553
- All records independent and self-documenting
- BIT: Power-on, commanded, periodic
- Two hold-downs on ARINC Type 6 case
- Configurable for new applications
- Cooling ducts for optional forced-air
- 100% ESS on all units
- Interfaces with L-3/EDI's crash survivable memory units up to 50 ft. away
- GSE available for test and download
- Spare slots and throughput available

The Flight Data Recorder Processor (FDRP) receives key vehicle, subsystem, and environmental parameters from up to six MIL-STD-1553 buses, and stores formatted records in an external memory unit such as L-3/EDI's Crash Survivable Memory Unit. The FDRP formats records for incident and mishap investigation, including 15-minute and 12-hour periodic and 12-hour aperiodic circular buffers plus a 44-event circular buffer. The FDRP was developed for the B-2 bomber but can be easily adapted to other vehicles.

The FDRP is a standard ARINC size 6 unit suitable for mounting in an avionics rack. It contains a 16-bit microprocessor, dual-redundant Remote Terminal interface, Bus Monitor interfaces for five MIL-STD-1553 buses and a power supply. This highly reliable unit has no analog signals and moving parts or adjustments.

The bus monitoring function receives and edits bus traffic on all buses simultaneously, saving user-specified messages at prescribed rates while also detecting complex exceedance events.

Unit built-in test is performed on power-up, on command and continuously. Downloading of flight data can be performed at any time over the MIL-STD-1553 bus or a dedicated RS-422 channel. The modular design of the FDRP permits fast, easy fault detection, isolation and repair in the field. Air ducts are provided for forced-air cooling, although the unit does not require forced air and will cool itself by convection.

L-3 Communications, ElectroDynamics, a leader in solid-state recorder technology, has also produced recorders for the B-1, F-4, F-22, and T-45 aircraft.

Flight Data Recorder Processor

DESIGN

MIL-E-5400—general
 MIL-STD-1553B—multiplex bus
 MIL-STD-704—aircraft power
 MIL-STD-810—environmental test
 MIL-STD-461/462—EMI
 RS-422—optional GSE interface
 Validated per RT and Monitor Validation Test Plans

SPECIFICATIONS

Size: 7.5" H x 7.62" W x 7.62" D
Weight: 17.25 lbs
Color: Lusterless gray
Power: +28 VDC @ 28 watts
MTBF: 15,000 hours (MIL-HDBK-217E)
MTTR: 1.25 hour
MMH/FH: .0001
Life: 15,000 hours operating, 30 years useful



FLIGHT DATA RECORDER PROCESSOR

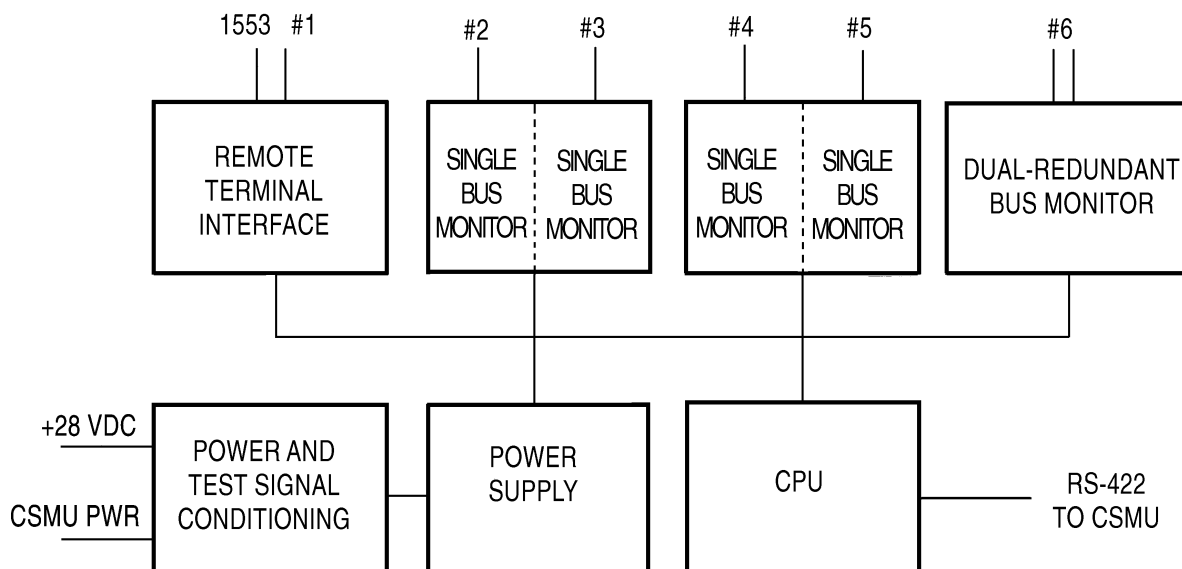

SYSTEMS