

# Miniature LED Indicator

## ML 1600/ML 1610



communications  
Electrodynamics, Inc.



### FEATURES

- Performs in Severe Environments
- Low Power Use
- Long Life
- High Efficiency
- High Luminosity
- Rugged Construction
- Readily Mounted on Panel

Designed for use as function indicators on aircraft, test equipment, machine tools and wherever severe environmental conditions need to be met.

### MECHANICAL SPECIFICATIONS

**Case:** black anodized aluminum.

**Mounting:** Front panel by 5/16-32" nut and lockwasher.

**Weight:** 1.5 grams with hardware.

**Seal:** Environmentally sealed. Added front panel O-ring seal for model ML 1610.

### ENVIRONMENTAL SPECIFICATIONS

**Operating Temperature Range:** -55°C to +100°C

**Vibration:** .06" D.A. or 20 G Peak, whichever is less, 10 Hz to 2 kHz, MIL STD 202, Method 204, Test Condition D.

**Shock:** 100 G's MIL STD 202, Method 213, Test Condition I.

**Moisture Resistance (Humidity):** MIL STD 202, Method 106.

**Altitude:** 100,000 ft., MIL STD 202, Method 105, Test Condition D.

**Life:** Operational 6 x 10<sup>6</sup> hours. min. MTBF @ 25°C and max. I, steady state.

**Salt Spray:** MIL STD 202, Method 101, Test Condition B.

### ELECTRO-OPTICAL CHARACTERISTIC SPECIFICATIONS

### Absolute Maximum Ratings

Color	Red	Yellow	Green	
Forward Voltage (VDC)	1.9	2.0	2.1	
Peak Forward Current (mA)	90	60	90	
DC Forward Current (mA)*	30	20	30	
Reverse Voltage (VDC) (I <sub>R</sub> =100μA)	5	5	5	
Power Dissipation (mW)	135	85	135	
Luminous Intensity (mcd) typical @ I <sub>f</sub> = 10 mA	Non Diffused Diffused	60 7.0	50 8.0	70 5.2
Dominant Wave Length (nm) typical	626	585	569	
Viewing Angle (2 Ø <sup>1/2</sup> ) typical	Non Diffused Diffused	35° 60°	35° 60°	35° 60°
Operating Temperature (°C)	-55 to +100	-55 to +100	-20 to +100	
Storage Temperature (°C)	-55 to +100	-55 to +100	-55 to +100	
Lead Soldering Temperature	260°C for 5 seconds			

\* For red and green, derate linearly from 50°C @ 0.5 mA/°C. For yellow, derate linearly from 50°C @ 0.2 mA/°C

### ORDERING INFORMATION

When ordering, show basic part number first, followed by the color of the LED, lens type and terminal style. If this is a special part, factory's modification number will be added at the end of the ordering number.

Example: A basic model with an o-ring panel seal, a yellow LED, a diffused lens, and loop terminals would be ML1610-Y-D-LT.

### ML 1610 - Y - D - LT - S ( )

Basic Model Number	LED Color	Lens Type	Terminal Style	Factory Modification Number if Special
ML1600 (w/o O-Ring)	(R) = Red (Y) = Yellow (G) = Green	(ND) = Non-diffused (D) = Diffused	ST = Straight Leads LT = Loop terminals	S.+ ID No.
ML1610 (with O-Ring)				

# Miniature LED Indicator

## ML 1600/ML 1610



ML 1600



ML1610 front



ML1610 back  
showing Front  
Panel O-Ring  
Seal

### Model ML 1600

Environmentally Sealed-No O-Ring

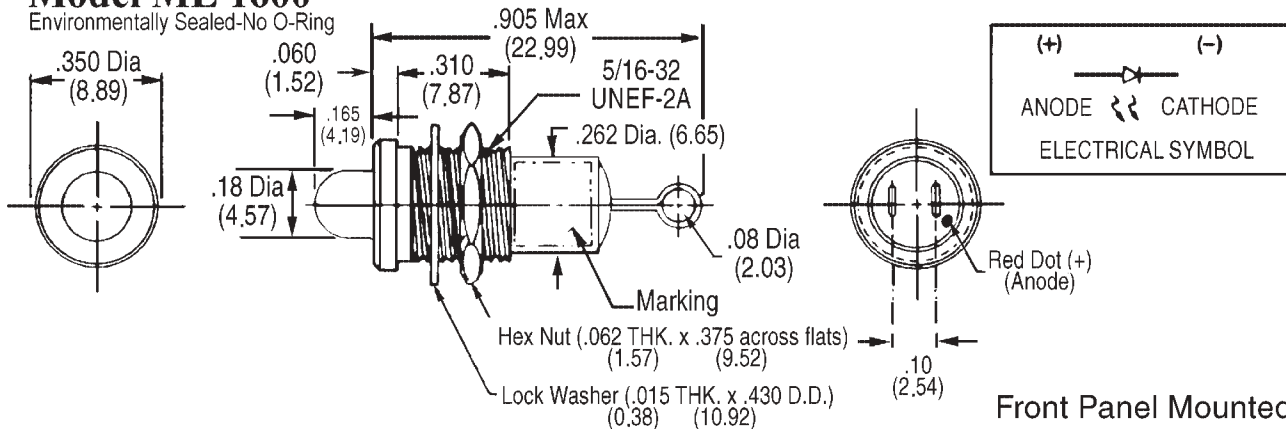

### Model ML 1610

Environmentally Sealed- With Front Panel O-Ring

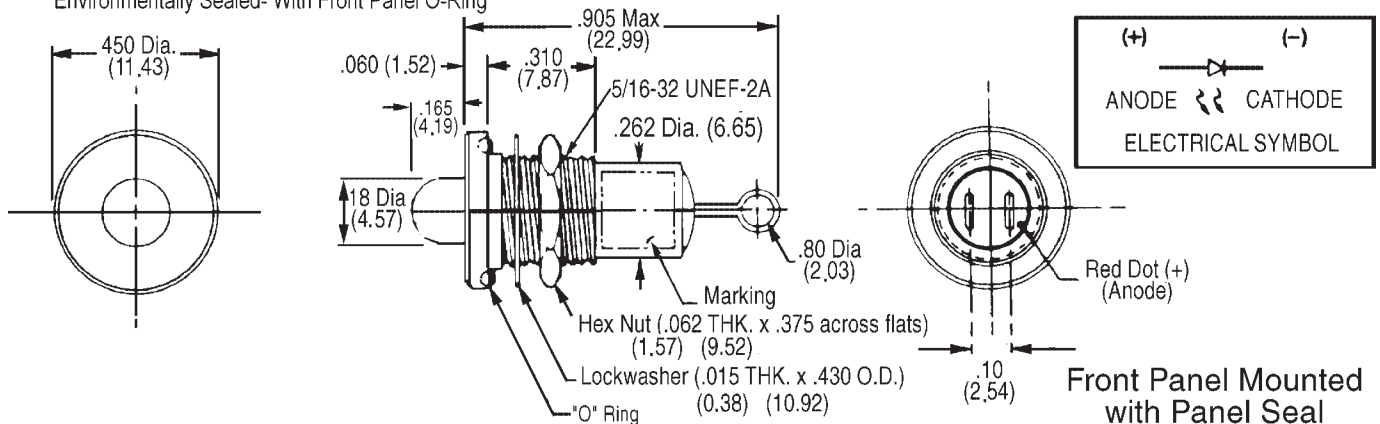

**NOTE:**

Dimensions in ( ) are mm.

Tolerances: Decimals:  $\pm .010$  (0,25)

Fractions:  $\pm 1/64$

Mounting Torque: 5-7 in. lbs.